

Installation Instruction

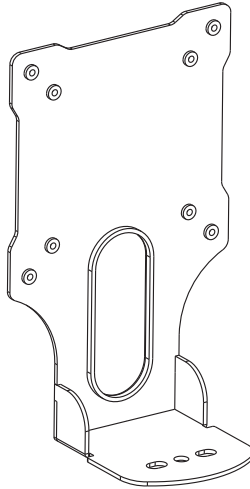

UNPACKING INSTRUCTIONS

- Carefully open the carton, remove contents and lay out on cardboard or other protective surface to avoid damage.
- Check package contents against the Supplied Parts List in the next page to assure that all components were received undamaged. Do not use damaged or defective parts.
- Carefully read all instructions before attempting installation.

IMPORTANT SAFETY INFORMATION

Install and operate this device with care. Please read this instruction before beginning the installation, and carefully follow all instructions contained herein. Use proper safety equipment during installation.

Please call a qualified installation contractor for help if you:

- If you don't understand these directions or have any doubts about the safety of the installation.
- If you are uncertain about the nature of your wall, consult a qualified installation contractor.

Do not use this product for any purpose or in any configuration not explicitly specified in this instruction. We hereby disclaims any and all liability for injury or damage arising from incorrect assembly, incorrect mounting, or incorrect use of this product.

Supplied Parts List

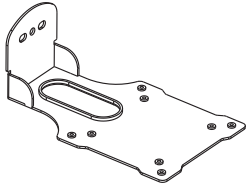

(1) Adaptor Bracket-a

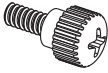

(4) M4x12 Thumb Bolt-b



(4) M6 Washer-c
(6x17x2mm)

Step 1

Remove Monitor Base

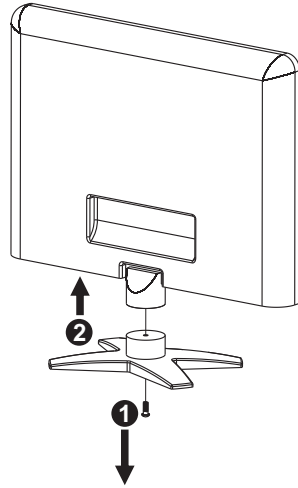

Remove the screw in the bottom of the base, and detach the base from the monitor.

Step 2

Attach Adaptor Bracket to Monitor

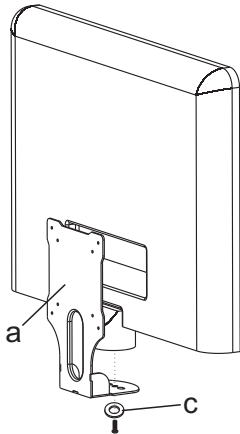

Position the base clip on the Adaptor Bracket(a) and insert the screw from step one into the center hole in the bottom of bracket. Tighten securely. If needed, use the included washers(c) to enable a more secure fit.

Step 3

Connect the Adaptor Bracket to VESA Plate

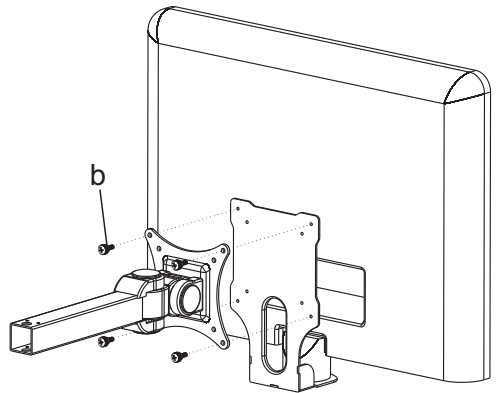

Connect the VESA plate to the Adaptor Bracket(a) using 4pcs M4x12 Thumb bolts(b).